

## Step-Up DC/DC Converter-Backlight LED Driver

## ■ GENERAL DESCRIPTION

The XC9116 series is a fixed frequency, constant current step-up DC/DC converter ideal for driving LEDs used in backlighting applications such as cellular phones, PDAs and digital cameras. Output voltage of up to 17.5V can be derived, therefore four white LEDs in series can be driven. Since an LED current can be set by an external resistor when LEDs are in-series connection, all white LEDs can be turned on equably. A network of two parallel legs with three in each LED can be also driven. Luminance of the LEDs is controlled by changing the duty cycle of a PWM signal applied to the CE pin. Efficiency is high with the low feedback reference voltage ensuring the RLED losses are minimal. In addition, an internal MOSFET with an  $R_{DS(ON)}$  of  $2.0\Omega$  is used. A low profile and small board area solution can be achieved using a chip coil and an ultra small ceramic output capacitor (CL) of  $0.22\mu\text{F}$  as a result of the high 1.0MHz switching frequency.

The 'B' type of XC9116 has an additional fault detection circuit. If the LEDs are disconnected or damaged, excess or run away output voltage is prevented by stopping the drive of the internal MOSFET.

## ■ APPLICATIONS

- For White LED drivers
- Mobile phones, PHS
- PDAs
- Digital still cameras

## ■ FEATURES

<b>Input Voltage Range</b>	: 2.5V ~ 6.0V
<b>Output Voltage Range</b>	: Up to 17.5V externally set-up : Reference voltage $0.2V \pm 5\%$
<b>Oscillation Frequency</b>	: 1.0MHz, $\pm 20\%$
<b>ON Resistance</b>	: $2.0\Omega$
<b>Efficiency</b>	: 86% (XC9116B Type) : 84% (XC9116D Type) ( $V_{IN}=3.6V$ , $I_{LED}=20\text{mA}$ when driving 3 white LEDs in series)
<b>Control</b>	: PWM control
<b>Standby current</b>	: $I_{STB}=1.0\mu\text{A}$ (MAX.)
<b>Load Capacitor</b>	: $0.22\mu\text{F}$ , ceramic
<b>Lx Limit Current</b>	: 325mA
<b>Lx Overvoltage Limit</b>	: XC9116B series
<b>No Lx Overvoltage Limit</b>	: XC9116D series
<b>Package</b>	: SOT-25, USP-6B
<b>Environmentally Friendly</b>	: EU RoHS Compliant, Pb Free

## ■ TYPICAL APPLICATION CIRCUIT

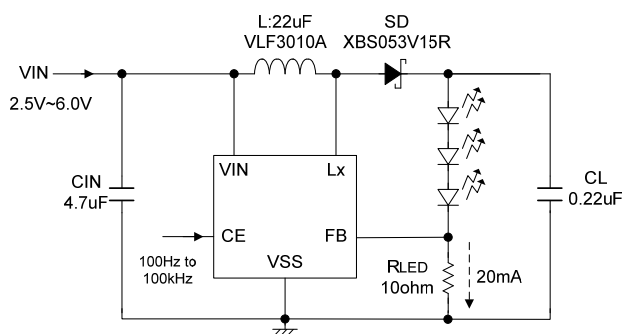

## ■ TYPICAL PERFORMANCE CHARACTERISTICS

## ● XC9116B Type

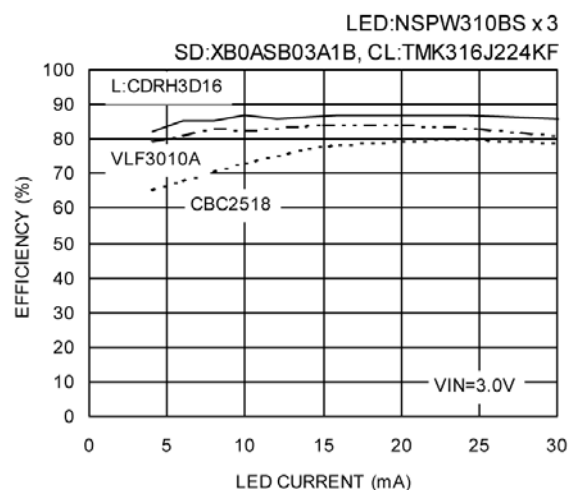

## PIN CONFIGURATION

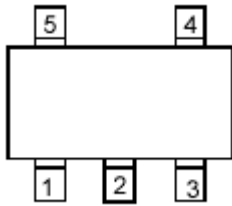

SOT-25 (TOP VIEW)

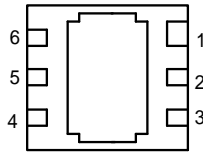

USP-6B (BOTTOM VIEW)

\*The dissipation pad of the USP-6B package should be left open. If the circuit needs to be connected to other pin, it should be connected to the Vss pin.

## PIN ASSIGNMENT

PIN NUMBER		PIN NAME	FUNCTION
SOT-25	USP-6B		
1	2	Lx	Switch
2	3	Vss	Ground
3	1	FB	Voltage Feedback
4	6	CE	Chip Enable
5	4	VIN	Power Input
-	5	NC	No Connection

## CE PIN FUNCTION

CE PIN	OPERATIONAL STATE
H	Operation
L	Shut-down

## PRODUCT CLASSIFICATION

### Ordering Information

XC9116①②③④⑤⑥-⑦<sup>(\*)</sup>

DESIGNATOR	DESCRIPTION	SYMBOL	DESCRIPTION
①	Lx Overvoltage Limit	B	Available
		D	Not available
②③	FB Voltage	02	0.2V
④	Oscillation Frequency	A	1MHz
⑤⑥-⑦	Packages Taping Type <sup>(*)</sup>	MR	SOT-25
		DR-G	USP-6B
		DR	USP-6B

<sup>(\*)</sup> The "-G" suffix indicates that the products are Halogen and Antimony free as well as being fully RoHS compliant.

<sup>(\*)</sup> The device orientation is fixed in its embossed tape pocket. For reverse orientation, please contact your local Torex sales office or representative. (Standard orientation: ⑤R-⑦, Reverse orientation: ⑤L-⑦)

## ■ BLOCK DIAGRAMS

### ● XC9116B02A

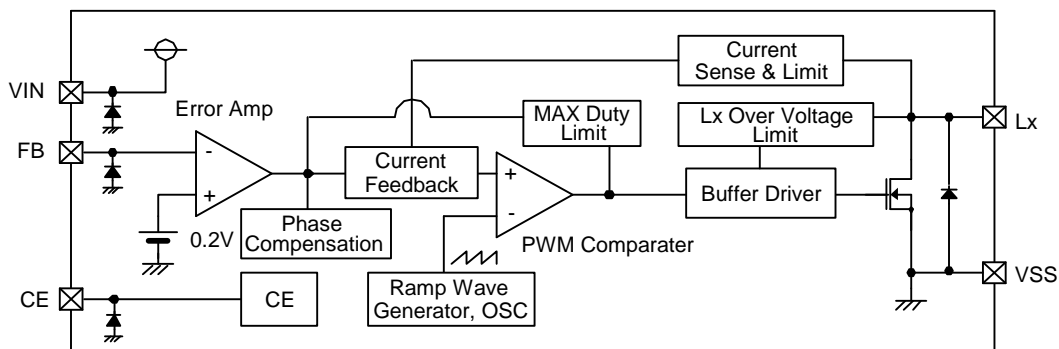

### ● XC9116D02A

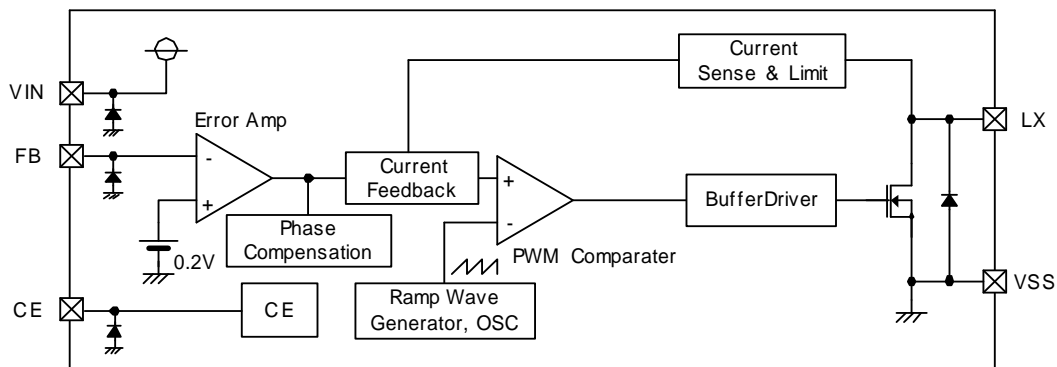

## ■ ABSOLUTE MAXIMUM RATINGS

Ta = 25°C

PARAMETER	SYMBOL	RATINGS	UNITS
VIN Pin Voltage	VIN	Vss - 0.3 ~ 7.0	V
Lx Pin Voltage	VLx	Vss - 0.3 ~ 22.0	V
FB Pin Voltage	VOUT	Vss - 0.3 ~ 7.0	V
CE Pin Voltage	VCE	Vss - 0.3 ~ 7.0	V
Lx Pin Current	ILx	1000	mA
Power Dissipation	SOT-25	250	mW
	USP-6B	120	
Operating Temperature Range	Topr	- 40 ~ + 85	°C
Storage Temperature Range	Tstg	- 55 ~ +125	°C

## ELECTRICAL CHARACTERISTICS

XC9116B02AMR

Ta = 25 °C

PARAMETER	SYMBOL	CONDITIONS	MIN.	TYP.	MAX.	UNIT.	CIRCUIT
FB Control Voltage	VFB	FB	0.19	0.20	0.21	V	①
Output Voltage Range	VOUTSET		VIN	-	17.5	V	①
Input Voltage Range	VIN		2.5	-	6.0	V	①
Supply Current 1	IDD1		-	450	750	μA	②
Supply Current 2	IDD2	VIN=Lx, VFB=0.4V	-	60	140	μA	③
Standby Current	I <sub>STB</sub>	V <sub>CE</sub> =0V, V <sub>LX</sub> =5.0V	-	0	1.0	μA	③
Oscillation Frequency	f <sub>OSC</sub>		0.8	1.0	1.2	MHz	②
Maximum Duty Cycle (*1)	MAXDTY		86	92	98	%	②
Efficiency (*2)	EFFI	When connected to ext. components, VIN=3.6V, R <sub>LED</sub> =20 Ω	-	86	-	%	①
Current Limit	ILIM	When connected to ext. components, VIN=3.6V	225	325	425	mA	④
Lx Overvoltage Limit	V <sub>LXOVL</sub>	Voltage which Lx pin voltage holding "H" level VIN ≥ 2.5V	18.0	19.0	22.0	V	②
Lx ON Resistance	R <sub>SWON</sub>	VIN=3.6V, V <sub>LX</sub> =0.4V	-	2.0	-	Ω	②
Lx Leakage Current	IL <sub>XL</sub>	Same as I <sub>STB</sub>	-	0	1.0	μA	③
CE "High" Voltage	V <sub>CEH</sub>	CE applied voltage when Lx starts oscillation	0.65	-	-	V	②
CE "Low" Voltage	V <sub>CEL</sub>	CE applied voltage which Lx pin voltage holding "H" level	-	-	0.2	V	②
CE "High" Current	I <sub>CEH</sub>	Same as ID <sub>D2</sub>	-0.1	-	0.1	μA	③
CE "Low" Current	I <sub>CEL</sub>	Same as I <sub>STB</sub>	-0.1	-	0.1	μA	③
FB "High" Current	I <sub>FBH</sub>	Same as ID <sub>D2</sub>	-0.1	-	0.1	μA	③
FB "Low" Current	I <sub>FBL</sub>	Same as I <sub>STB</sub>	-0.1	-	0.1	μA	③

Unless otherwise stated, VIN=3.0V, V<sub>CE</sub>=3.0V, V<sub>FB</sub>=0V, V<sub>PULL</sub>=5.0V

NOTE: \*1: The duty ratio is forcibly reduced when maximum duty cycle periods are repeated.

\*2: LED : NSPW310BS x 3, EFFI = {[(output voltage) x (output current)] / [(input voltage) x (input current)]} x 100

XC9116D02AMR

Ta = 25 °C

PARAMETER	SYMBOL	CONDITIONS	MIN.	TYP.	MAX.	UNIT	CIRCUIT
FB Control Voltage	VFB	FB	0.19	0.20	0.21	V	①
Output Voltage Range	VOUTSET		VIN	-	19.5	V	①
Lx Operating Voltage Range	V <sub>LX</sub>		-	-	20.0	V	①
Operating Voltage Range	VIN		2.5	-	6.0	V	①
Supply Current 1	IDD1		-	450	750	μA	②
Supply Current 2	IDD2	VIN=Lx, VFB=0.4V	-	50	120	μA	③
Standby Current	I <sub>STB</sub>	V <sub>CE</sub> =0V, V <sub>LX</sub> =5V	-	0	1.0	μA	③
Oscillation Frequency	f <sub>OSC</sub>		0.8	1.0	1.2	MHz	②
Maximum Duty Cycle	MAXDTY		86	92	98	%	②
Efficiency (*1)	EFFI	When connected to ext. components, VIN=3.6V, R <sub>LED</sub> =20 Ω	-	84	-	%	①
Current Limit	ILIM	When connected to ext. components, VIN=3.6V	225	325	425	mA	④
Lx ON Resistance	R <sub>SWON</sub>	VIN=3.6V, V <sub>LX</sub> =0.4V, R <sub>PULL</sub> =10 Ω	-	2.0	3.6	Ω	②
Lx Leakage Current	IL <sub>XL</sub>	Same as I <sub>STB</sub>	-	0	1.0	μA	③
CE "High" Voltage	V <sub>CEH</sub>	CE applied voltage when Lx starts oscillation	0.65	-	-	V	②
CE "Low" Voltage	V <sub>CEL</sub>	CE applied voltage which Lx pin voltage holding "H" level	-	-	0.2	V	②
CE "High" Current	I <sub>CEH</sub>	Same as ID <sub>D2</sub>	-0.1	-	0.1	μA	③
CE "Low" Current	I <sub>CEL</sub>	Same as I <sub>STB</sub>	-0.1	-	0.1	μA	③
FB "High" Current	I <sub>FBH</sub>	Same as ID <sub>D2</sub>	-0.1	-	0.1	μA	③
FB "Low" Current	I <sub>FBL</sub>	Same as I <sub>STB</sub>	-0.1	-	0.1	μA	③

Test conditions: Unless otherwise stated, VIN=3.0V, V<sub>CE</sub>=3.0V, V<sub>FB</sub>=0V, V<sub>PULL</sub>=5.0V, R<sub>PULL</sub>=100 Ω

Notes: \*1: LED : NSPW310BS x 3, EFFI = {[(output voltage) x (output current)] / [(input voltage) x (input current)]} x 100

## TYPICAL APPLICATION CIRCUITS

●XC9116B02A

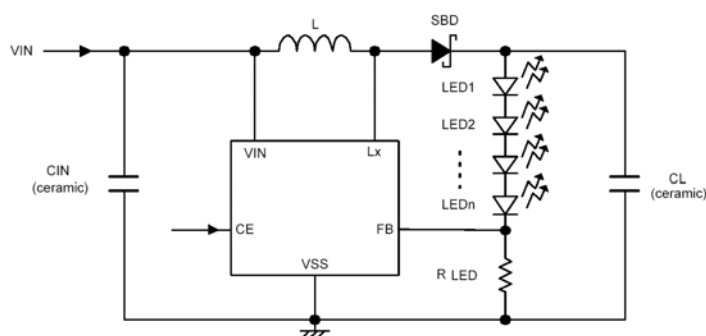

●XC9116D02A

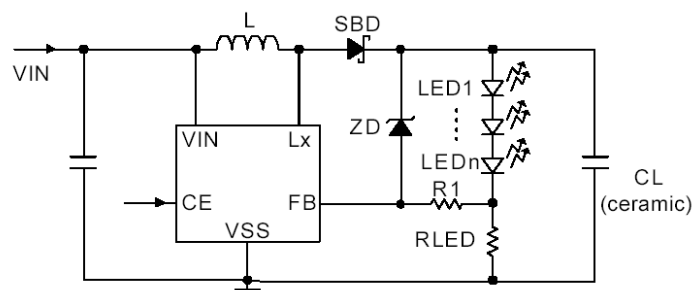

## EXTERNAL COMPONENTS

SYMBOL	VALUE	PART NUMBER	MANUFACTURER
L	22 $\mu$ H	VLF3010A-220MR	TDK
SBD (*1)	-	XBS053V15R-G (*2)	TOREX
		MA2Z720	PANASONIC
CIN	4.7 $\mu$ F	JMK107BJ475MA-B	TAIYO YUDEN
CL (*3)	0.22 $\mu$ F	TMK107BJ224KA-B	TAIYO YUDEN
ZD (*4)	18V	MAZ8180	PANASONIC
R1	100 $\Omega$	-	-

### NOTE :

- \*1: Please use a Schottky barrier diode (SBD) with a low junction capacitance, Cj.
- \*2: For using the XBS053V15R-G with four white LEDs in series, please be noted with a direct reverse voltage ( $V_R=20V$ ) and a repetitive peak reverse voltage ( $V_{RM}=30V$ ).
- \*3: Use ceramic capacitors processing a low temperature coefficient.
- \*4: Please refer to the LED Open-circuit Protection at Application Information for setting the Zener diode.

## OPERATIONAL EXPLANATION

The series consists of a reference voltage source, ramp wave circuit, error amplifier, PWM comparator, phase compensation circuit, Lx overvoltage limit circuit, N-channel MOS driver transistor, current limiter circuit and others. The series ICs compare, using the error amplifier, the voltage of the internal voltage reference source with the feedback voltage from the FB pin. Phase compensation is performed on the resulting error amplifier output, to input a signal to the PWM comparator to determine the turn-on time during switching. The PWM comparator compares, in terms of voltage level, the signal from the error amplifier with the ramp wave from the ramp wave circuit, and delivers the resulting output to the N-channel MOS driver transistor to cause the Lx pin to output a switching duty cycle. This process is continuously performed to ensure stable output voltage. The current feedback circuit detects the N-channel MOS driver transistor's current for each switching operation, and modulates the error amplifier output signal. This enables a stable feedback loop even when a low ESR capacitor, such as a ceramic capacitor, is used, ensuring stable output voltage.

### <Reference Voltage Source>

The reference voltage source provides the reference voltage to ensure stable output voltage of the IC.

### <Ramp Wave Circuit>

The ramp wave circuit determines switching frequency. The 1MHz (TYP.) of frequency is fixed internally. Clock pulses generated in this circuit are used to produce ramp waveforms needed for PWM operation.

### <Error Amplifier>

The error amplifier is designed to monitor output voltage. The amplifier compares the reference voltage with the FB pin voltage. When a voltage lower than the reference voltage is fed back, the output voltage of the error amplifier is increased. Gain and frequency characteristics of the error amplifier output are fixed internally as an optimize signal.

## OPERATIONAL EXPLANATIONS (Continued)

### <Current Limit>

The current limit circuit of the XC9116 series monitors the current flowing through the N-channel MOS driver transistor connected to the Lx pin, and features a combination of the constant-current type current limit mode and the duty cycle limit of the next pulse.

- ①When the driver current is greater than a specific level, the constant-current type current limit function operates to turn off the pulses from the Lx pin at any given timing.
- ②The IC controls the next pulse to be smaller than the first pulse.

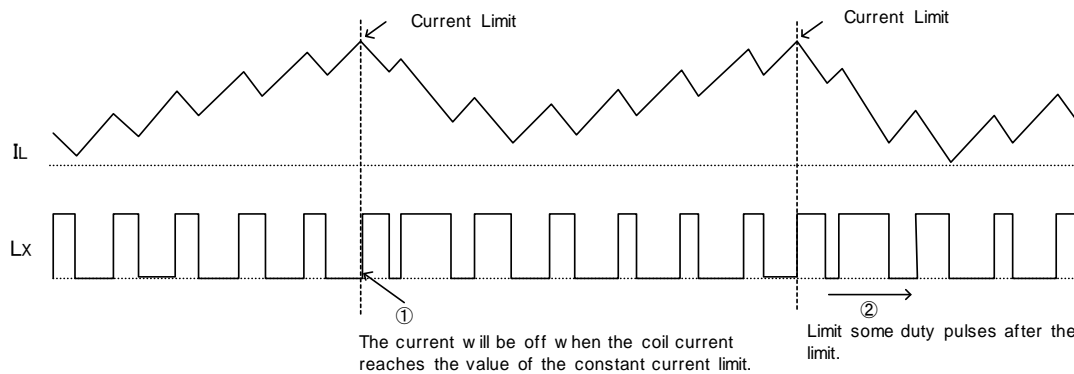

### <Lx Overvoltage Limit Circuit>

XC9116B series' Lx overvoltage limit circuit monitors the Lx pin voltage. When the Lx pin voltage exceeds than 19V (TYP.), the IC performs the function of latching the OFF state of the driver transistor, and goes into operation suspension mode. In suspension mode, operations can be resumed by restoring power to the VIN pin. The suspension mode does not mean a complete shutdown, but a state in which pulse output is suspended; therefore, the internal circuitry remains in operation.

### <Maximum Duty Cycle Limit>

The XC9116B series' maximum duty cycle limit circuit monitors the duty cycle. When the maximum duty cycle is repeated for a certain time, the IC controls the error amplifier output so that the duty cycle of the next pulse becomes smaller than that of the first pulse.

### <CE Pin Function>

The operation of the XC9116 series will enter into the shut down mode when a low level signal is input to the CE pin. During the shut down mode, the supply current is 0 μA (TYP.), with high impedance at the Lx pin. The IC starts its operation with a high level signal to the CE pin. The input to the CE/MODE pin is a CMOS input and the sink current is 0 μA (TYP.). 100 μs after disable, the IC goes into suspension mode and supply current is minimal. After this, the IC will be in stand-by mode and the supply current will be 0 μA (TYP.).

## NOTES ON USE

### <Lx (Pin 1): Switch Pin>

Please connect the anode of a Schottky barrier diode and an inductor to the Lx pin.

### <FB (Pin 3): Voltage Feedback Pin>

The reference voltage is 200mV (TYP.). A resistor (RLED) should be connected to the FB pin for setting the cathode of LEDs and a constant current value. The resistance value can be calculated by the following equation.

$$R_{LED} = 0.2 / I_{LED}$$

I<sub>LED</sub> = Setting constant current value

Typical example:

I <sub>LED</sub>	R <sub>LED</sub>	I <sub>LED</sub>	R <sub>LED</sub>
5mA	40 Ω	13.3mA	15 Ω
10mA	20 Ω	20mA	10 Ω

### <CE (Pin 4): Chip Enable Pin>

An ENABLED state is reached when the CE voltage exceeds 0.65V and a DISABLED state when the CE Voltage falls below 0.2V.

### <VIN (Pin 5): Power Supply Pin>

Please connect an inductor and an input by-pass capacitor (C<sub>IN</sub>) to the VIN pin.

## ■ APPLICATION INFORMATION

### <Dimming Control>

#### 1. Applying PWM signal to the CE pin

The XC9116 repeats on/off operations by a PWM signal applied to the CE pin. The magnitude of LED current,  $I_{LED}$ , when the diode is on, is determined by  $R_{LED}$ . The magnitude is zero when the diode is off. The average of LED current is proportional to the positive duty ratio of the PWM signal.

The frequency of the PWM signal can be controlled to the optimum value between 100Hz and 10kHz. With regard to the amplitude of the PWM signal, the high level should be higher than the "H" voltage of CE,  $V_{CEH}$ , and the low level, lower than the "L" voltage of CE,  $V_{CEL}$ .

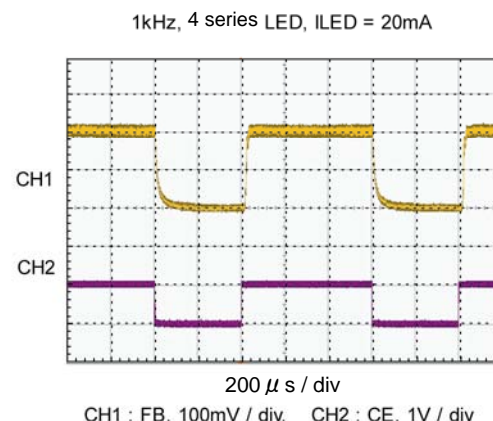
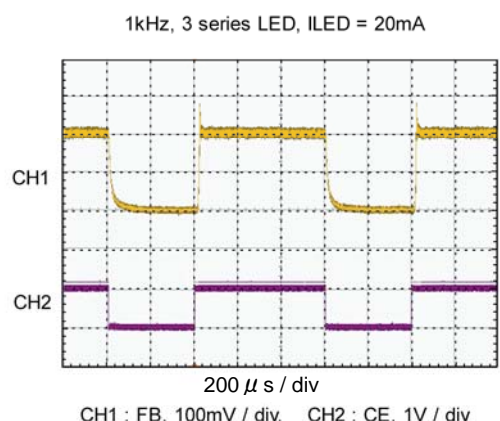
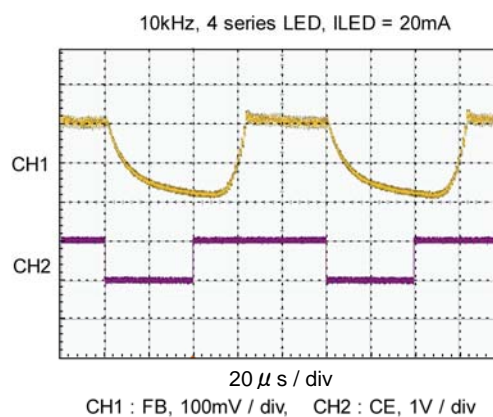
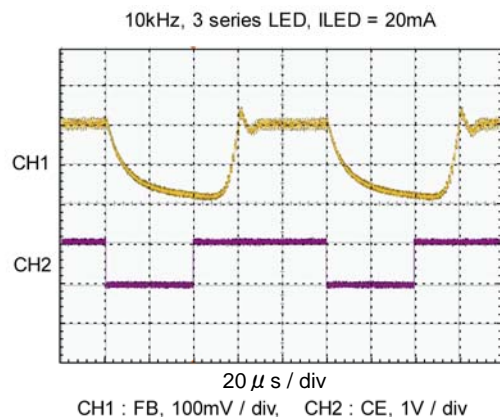

#### 2. Step-Wise Regulation of LED Current

In some applications, it may be necessary to incorporate step-wise regulation of LED current,  $I_{LED}$ . Step-wise regulation of LED illumination is achieved by connecting a switch element SW1 in parallel with  $R_{LED}$  and in series with  $R_{LED1}$  and turning SW1 on and off, as shown below. Choose a resistance of  $R_{LED}$  so that the minimum necessary current is gained when switch element SW1 is off. The resistance of  $R_{LED1}$  should be such that a desired increase of current passed through the LED is gained when the switch element is on.

Ex.) Current  $I_{LED} = 5mA$  and  $15mA$   
 $R_{LED} = 200mV / 5mA = 40 \Omega$   
 $R_{LED1} = 200mV / (15mA - 5mA) = 20 \Omega$

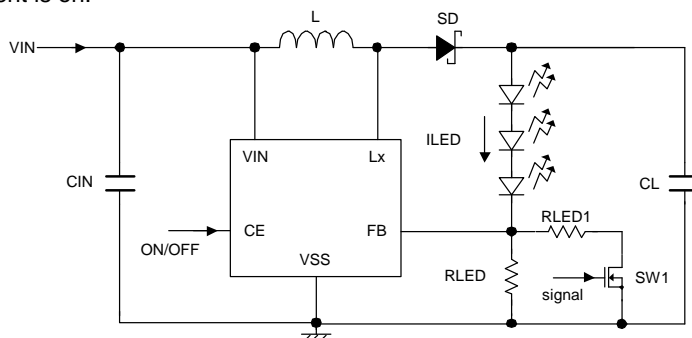

Figure : Circuit using Step-wise Regulation of LED Current

## APPLICATION INFORMATION (Continued)

<Dimming Control (Continued)>

### 3. Using DC Voltage

If in an application it is necessary to control the LED current by a variable DC voltage, illumination control of LED is achieved by connecting R1 and R2 and applying a direct-current voltage to R2, as shown below.

When  $R1 \gg RLED$ ,  $I_{LED}$  which flows into LEDs can be calculated by the following equation;

$$I_{LED} = (V_{REF} - R1 / R2 (V_{DC} - V_{REF})) / R_{LED}$$

$$V_{REF} = 0.2V \text{ (TYP.)}$$

Ex.1) When  $R1 = 10k\Omega$ ,  $R2 = 100k\Omega$ ,  $R_{LED} = 10\Omega$ ,  
In the range of 0.2V to 2.2V DC,  $I_{LED}$   
(LED current) varies between 20mA to 0mA.

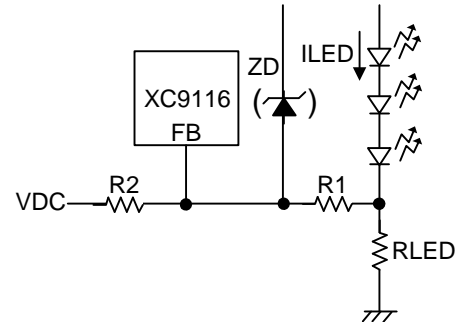

Figure : Circuit using DC voltage

Ex.2) When  $R1 = 10k\Omega$ ,  $R2 = 100k\Omega$ ,  $R3 = 10k\Omega$ ,  
 $C1 = 0.1\mu F$ ,  $R_{LED} = 10\Omega$ , the average LED current will  
be 10mA by inputting a PWM signal of CE 'H' level:  
2.2V, CE 'L' level: 0V, duty cycle: 50%, oscillation  
frequency: 100Hz. As well as the way of dimming  
control by applying the PWM signal to the CE pin, the  
average LED current increases proportionally with the  
positive duty cycle of the PWM signal.

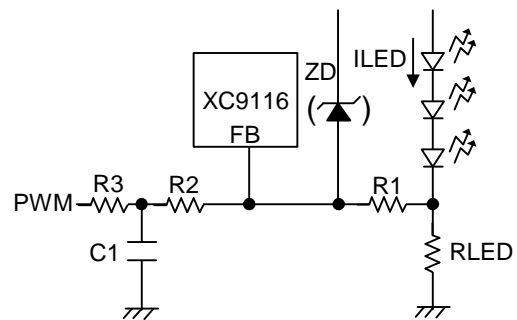
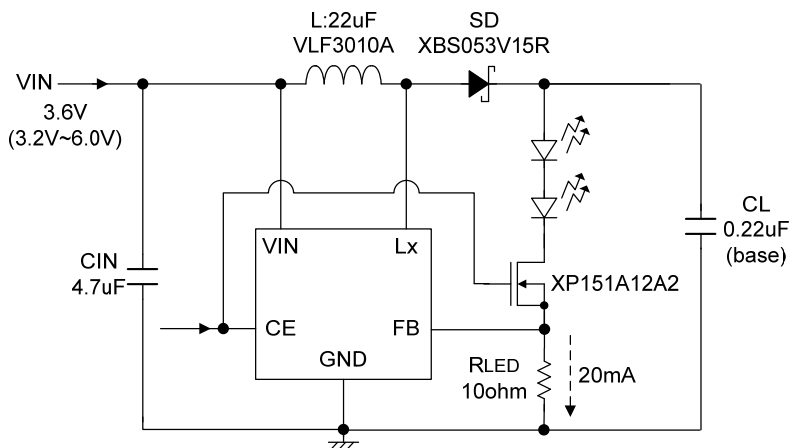

Figure : Circuit inputting a PWM signal to the FB pin

<Prevent Emission Caused by White LEDs Leakage>

When the input voltage ( $V_{IN}$ ) is high, minimum illumination may occur even if the CE pin is in the disable state. If this happens, please connect a transistor to between the LED and the FB pin. By driving the CE signal in-phase and cutting the pass to current, the minimum illumination can be prevented.





## APPLICATION INFORMATION (Continued)

### <Illumination of Six in Total White LEDs>

It is possible to illuminate three-series two parallel white LEDs, six in total, using an input voltage  $V_{IN} \geq 3.2V$ .

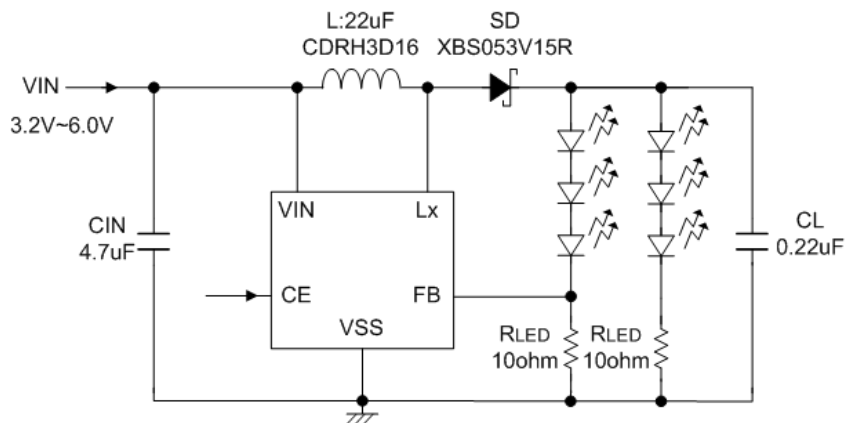

### <Use as Flash>

An LED current 65mA (MAX.) can be supplied to two white LEDs.

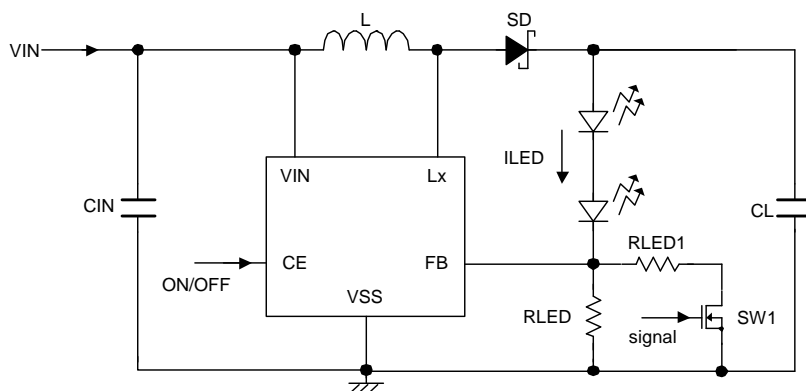

### <Separate Supply Source of the Step-up Circuit ( $V_{IN}$ ) from $V_{IN}$ Pin>

Supply source of the step-up circuit can be used separately from  $V_{IN}$  pin.

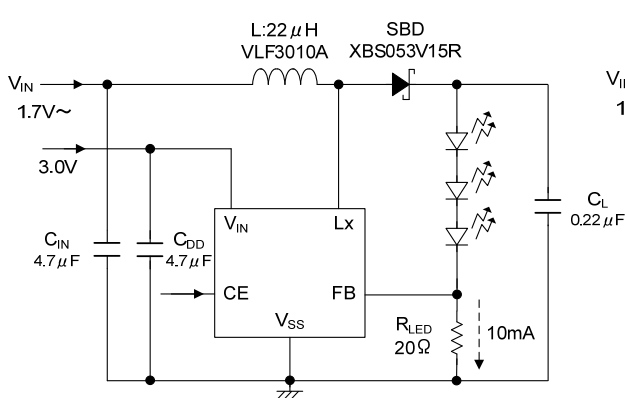

Circuit example of separating supply source of the step-up circuit from  $V_{IN}$  pin ( 3 LEDs)

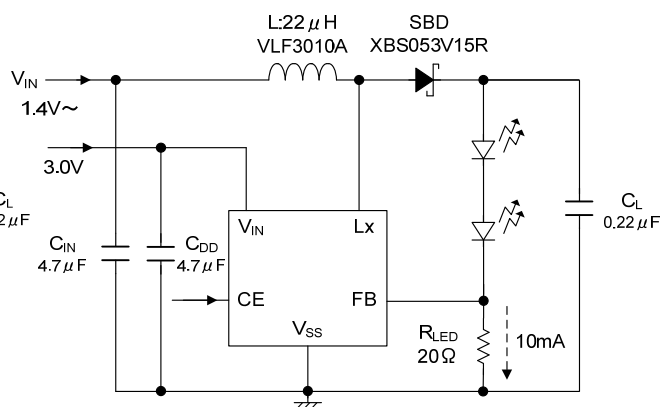

Circuit example of separating supply source of the step-up circuit from  $V_{IN}$  pin ( 2 LEDs)

Note: Please input 2.5V~6V to the  $V_{IN}$  pin when you use.

## APPLICATION INFORMATION (Continued)

### <LED Open-circuit Protection>

If white LEDs are opened or damaged, the FB pin is pulled down, so that the operating duty ratio reaches the maximum. Accordingly, the output voltage continues to increase, possibly causing the Lx pin voltage to exceed the absolute maximum rating of 22V.

In the case of the B type products, if white LEDs are opened or damaged, the detector built in the Lx pin causes the IC to stop oscillating, preventing excessive increase of the output voltage. However, the detector may detect an overvoltage if the Lx pin voltage exceeds 18V, which is the overvoltage limit, even when no LEDs are open. Therefore, care must be taken if four LEDs each having a forward voltage of 4.45V or more are connected in series.

In the case of the D type products (no overvoltage limit circuit), a Zener diode (ZD) and a resistor (R1) can be externally connected to serve as a load in the case that LEDs are opened, preventing the increase of the Lx pin voltage. The ZD voltage should be set to no more than 20V and no less than the product of each white LED's maximum forward voltage multiplied by the number of the connected LEDs, so that the Zener diode will not load the LEDs during normal operation. If the Zener diode becomes load, the current that runs through the white LEDs is reduced, decreasing illumination.

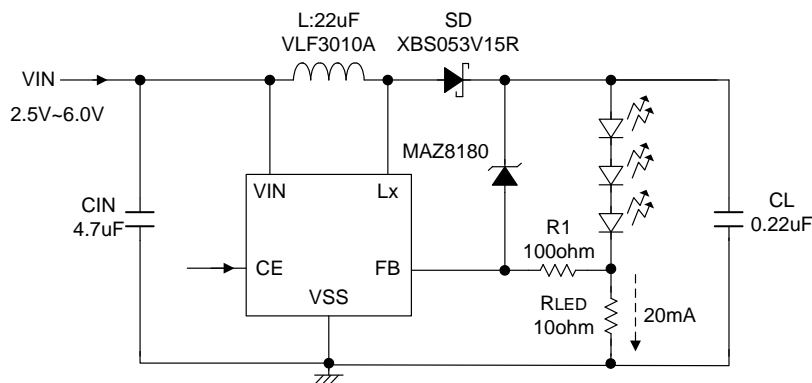

Note : The XC9116B02A series requires neither the Zener diode (ZD) nor the resistor 1 (R1).

### <Startup Inrush Current>

The XC9116 series has no soft-start circuit built-in in order to minimize delay at startup. The inrush current can reach up to the current limit,  $I_{LIM}$ .

In some cases, overshoot can occur.

## APPLICATION INFORMATION (Continued)

### <Instruction on Pattern Layout>

1. In order to stabilize  $V_{IN}$ 's voltage level, we recommend that an input by-pass capacitor ( $C_{IN}$ ) be connected as close as possible to the  $V_{IN}$  &  $V_{SS}$  pins.
2. Please mount each external component as close to the IC as possible.
3. Wire external components as close to the IC as possible and use thick, short connecting traces to reduce the circuit impedance.
4. Make sure that the PCB GND traces are as thick as possible, as variations in ground potential caused by high ground currents at the time of switching may result in instability of the IC.

### ●XC9116B Series Pattern Layout (SOT-25)

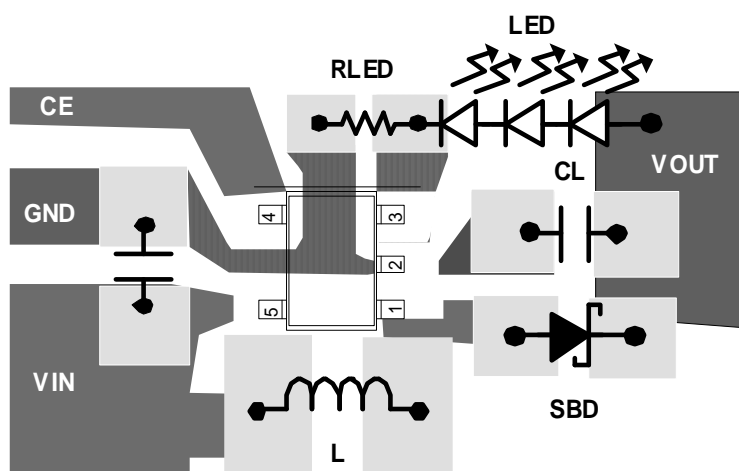

### ●XC9116D Series Pattern Layout (SOT-25)

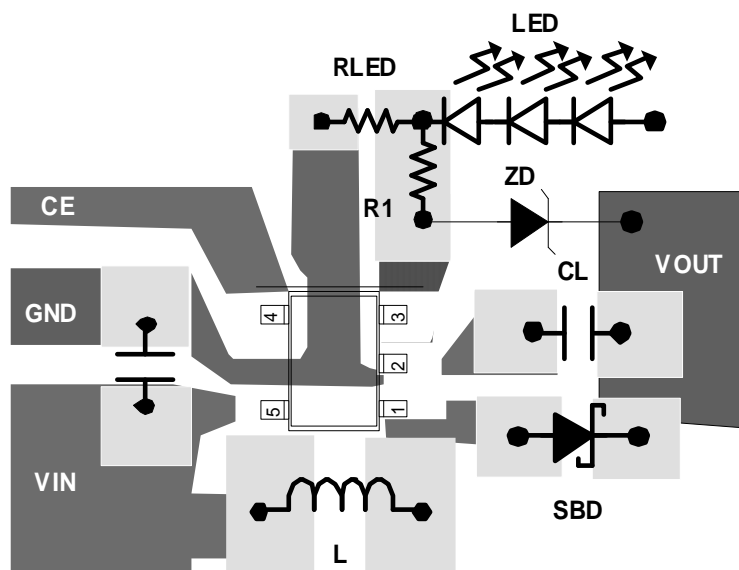

## TEST CIRCUITS

●Circuit ① XC9116B02A series

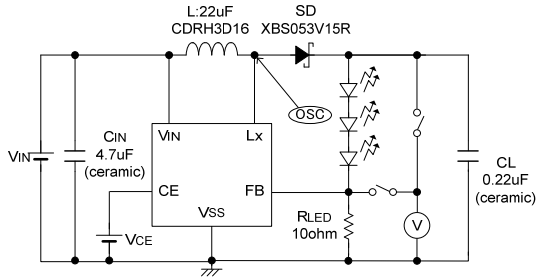

●Circuit ① XC9116D02A series

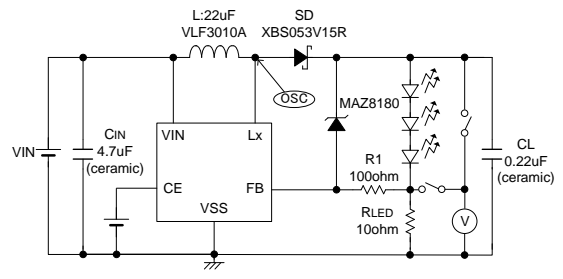

●Circuit ②

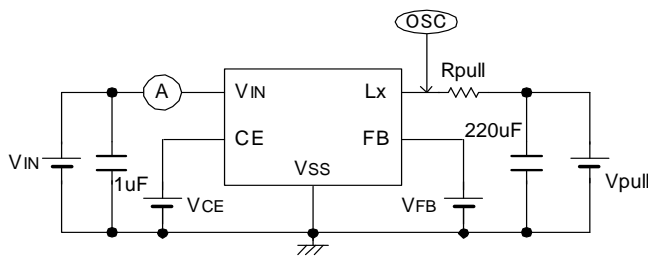

●Circuit ③

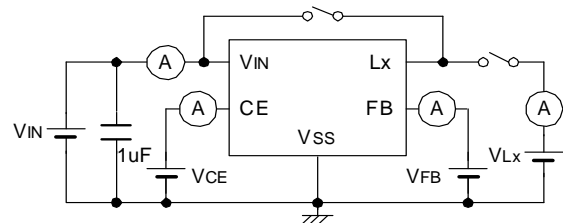

●Circuit ④

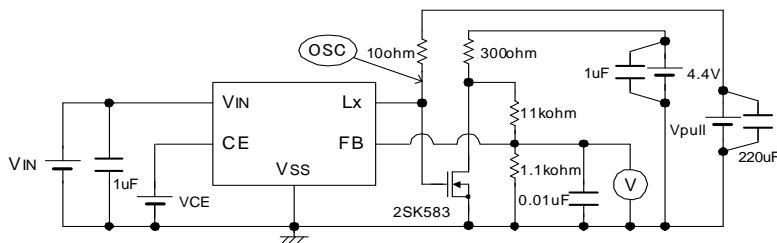

### 1. The measurement method of LX ON Resistance R<sub>SWON</sub>

Using the circuit ②, Lx ON resistance can be measured by adjusting V<sub>pull</sub> voltage to set Lx voltage V<sub>Lx</sub> 0.4V when the driver transistor is ON.

The oscilloscope is used for measuring the Lx voltage when the driver transistor is ON.

$$R_{SWON} = 0.4 / ((V_{pull} - 0.4) / 10)$$

### 2. The measurement method of current limit I<sub>LIM</sub>

Using the circuit ④, current limit I<sub>LIM</sub> can be calculated by the equation including V<sub>pull</sub> voltage when FB voltage is decreased while V<sub>pull</sub> voltage is adjusted and Lx voltage V<sub>Lx</sub> when the driver transistor is ON.

The oscilloscope is used for measuring the Lx voltage when the driver transistor is ON.

$$I_{LIM} = (V_{pull} - V_{Lx}) / R_{pull}$$

## ■ TYPICAL PERFORMANCE CHARACTERISTICS

(1) Supply Current 1 vs. Input Voltage

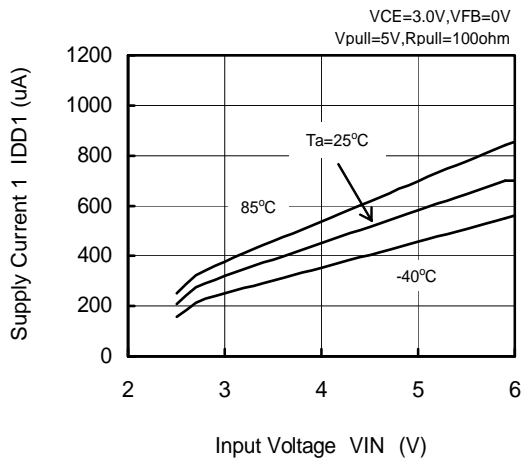

(2) Supply Current 2 vs. Input Voltage

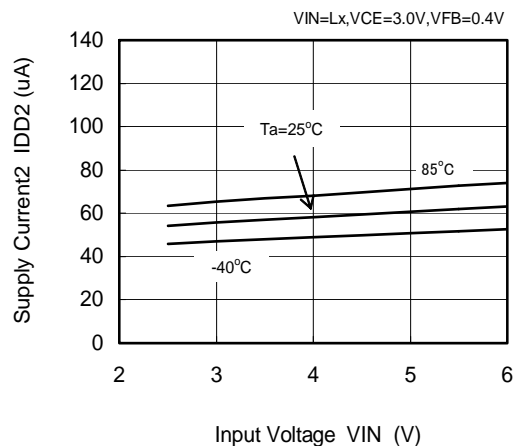

(3) Oscillation Frequency vs. Input Voltage

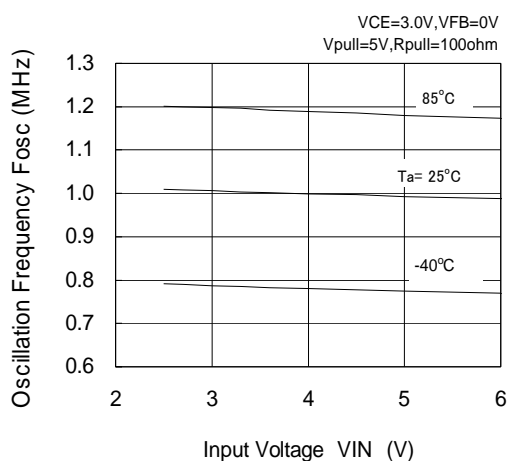

(4) Maximum Duty Cycle vs. Input Voltage

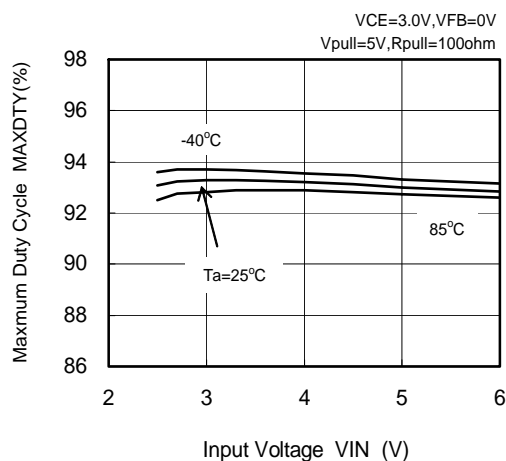

(5) Stand-by Current vs. Input Voltage

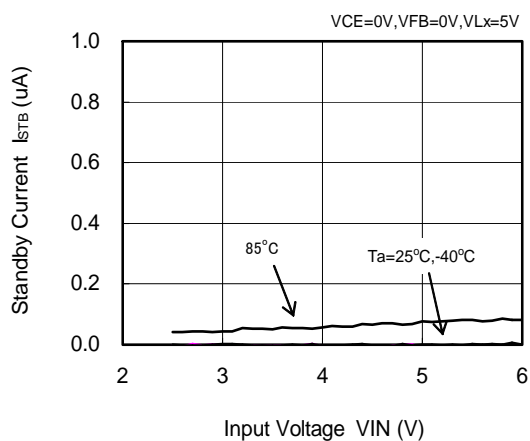

(6) Maximum LED Current vs. Input Voltage

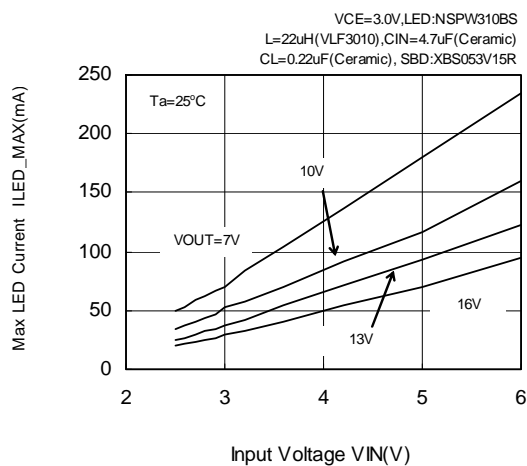

## TYPICAL PERFORMANCE CHARACTERISTICS (Continued)

(7) Lx On Resistance vs. Input Voltage

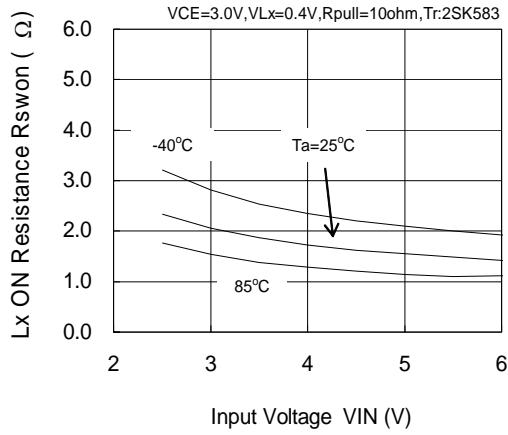

(8) Current Limit vs. Input Voltage

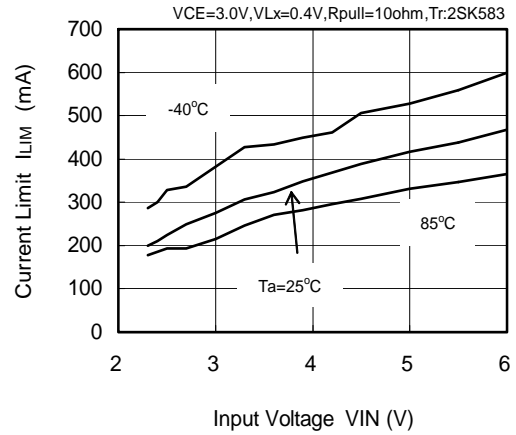

(9) FB Voltage vs. Ambient Temperature

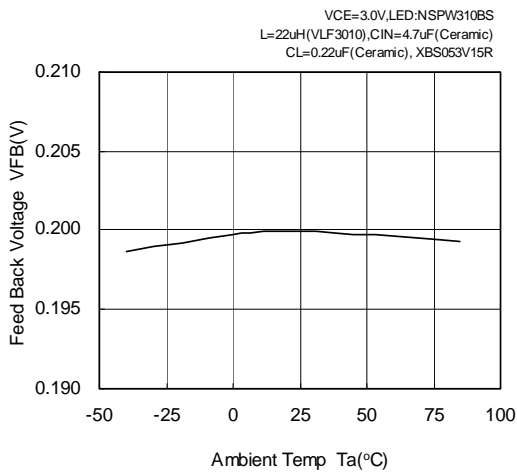

(10) Lx Overvoltage Limit vs. Input Voltage

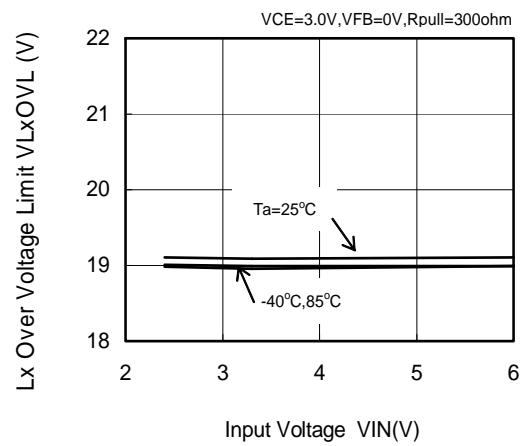

(11) CE 'H' Voltage vs. Input Voltage

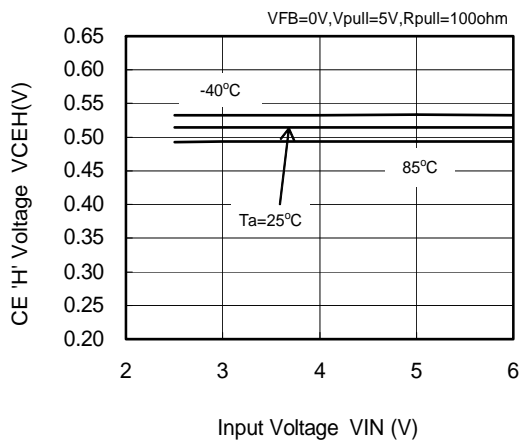

(12) CE 'L' Voltage vs. Input Voltage

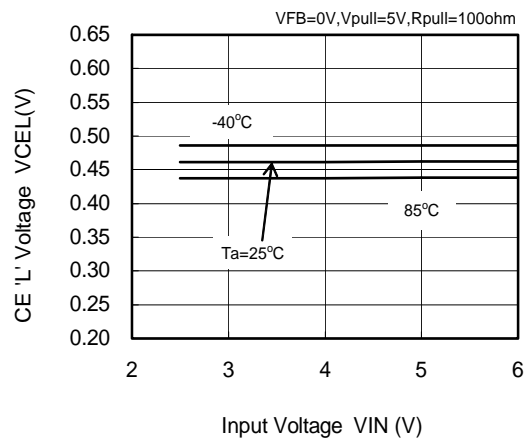

## ■ TYPICAL PERFORMANCE CHARACTERISTICS (Continued)

### (13) Efficiency vs. Input Voltage

○XC9116B02AMR, 3 LEDs in series

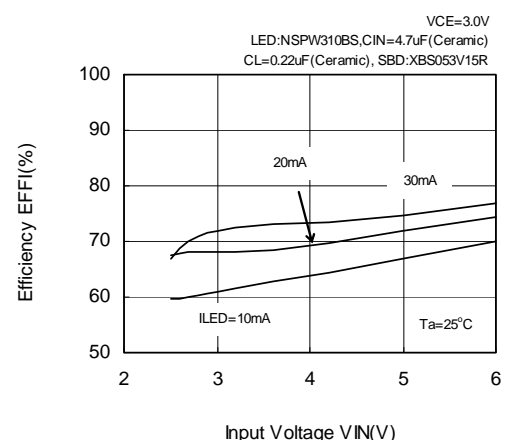
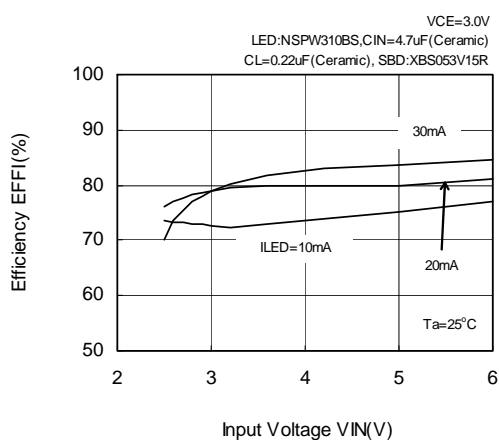
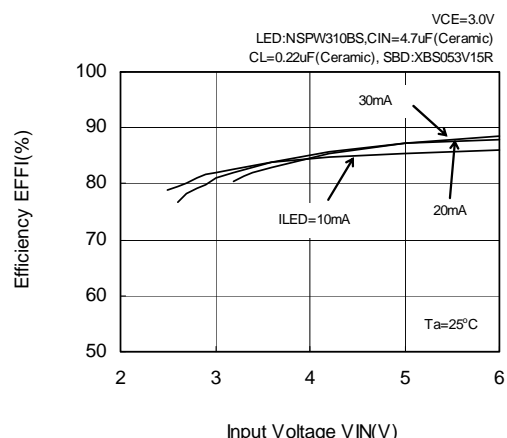
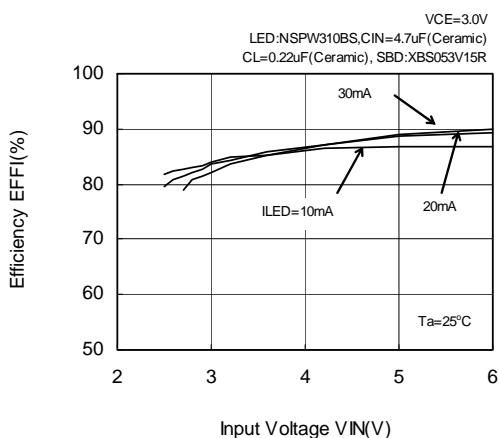
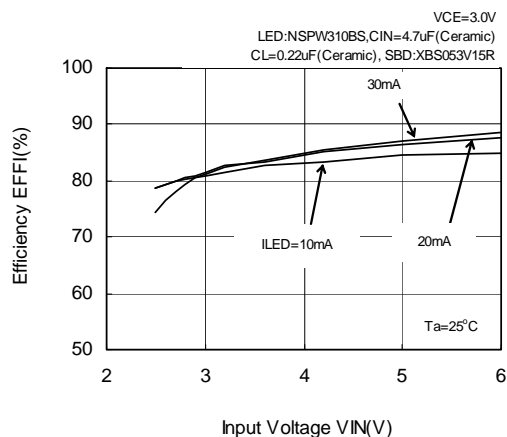
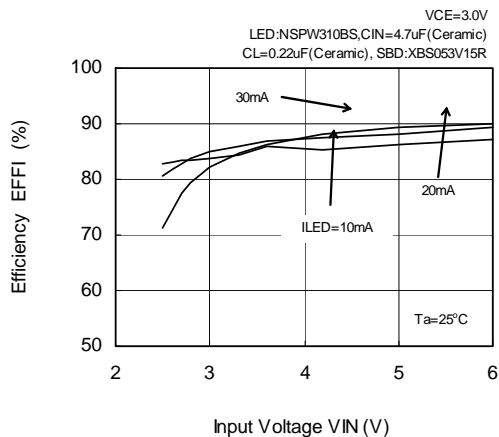

## TYPICAL PERFORMANCE CHARACTERISTICS (Continued)

(13) Efficiency vs. Input Voltage (Continued)

○XC9116B02AMR, 4 LEDs in series

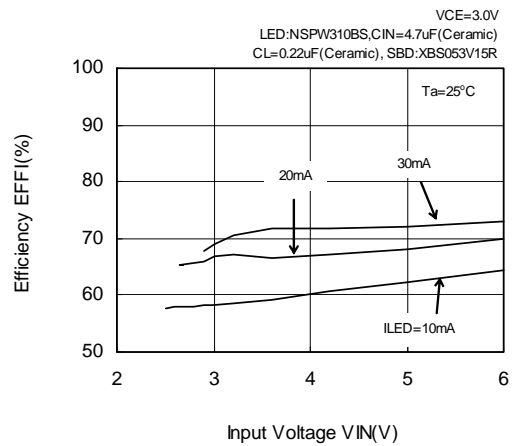
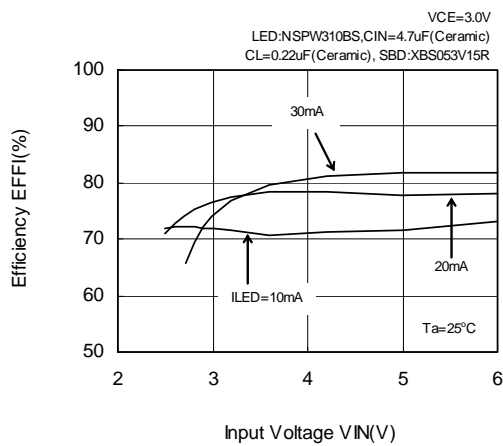
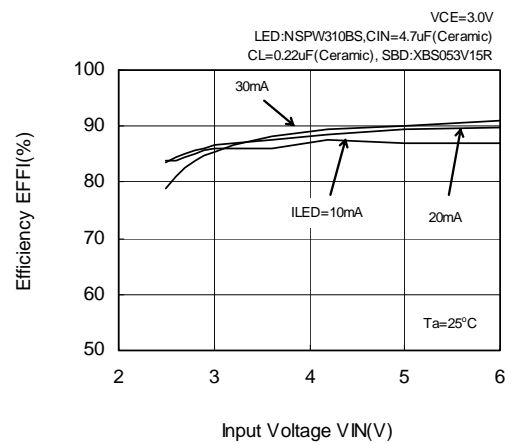
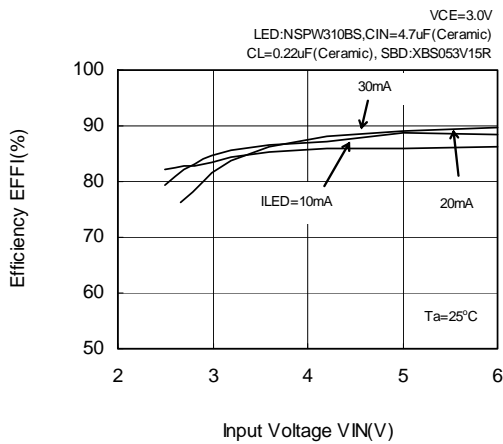
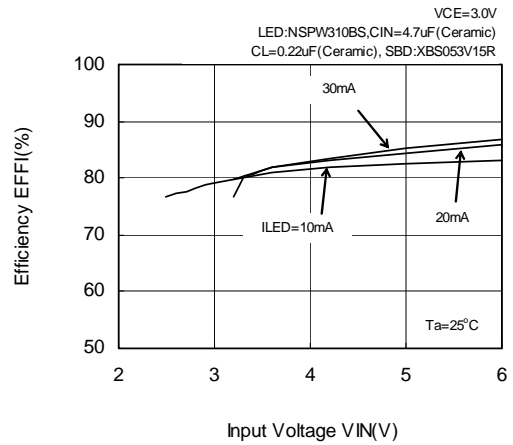
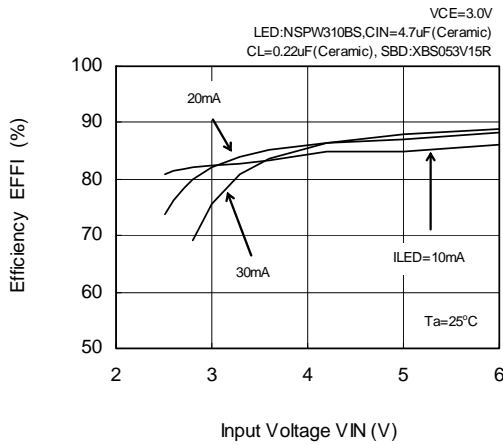



## ■ TYPICAL PERFORMANCE CHARACTERISTICS (Continued)

(13) Efficiency vs. Input Voltage (Continued)

○XC9116B02AMR, 2 parallel legs with 3 LEDs per leg

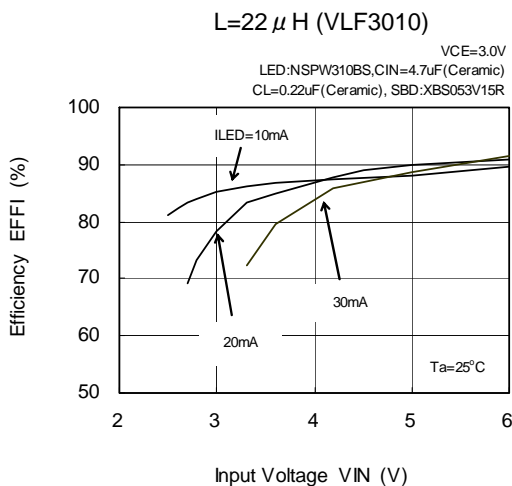

(14) Efficiency vs. LED Current

○XC9116B02AMR, 3 LEDs in series

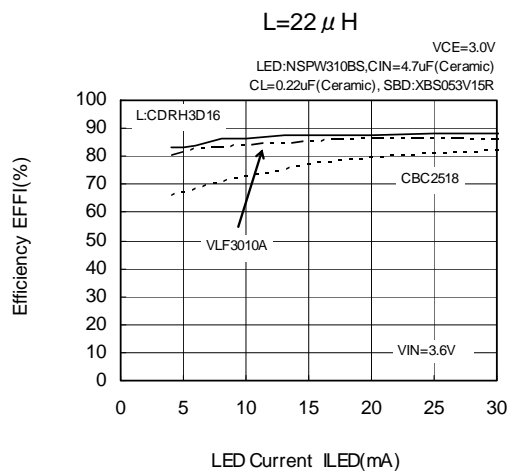
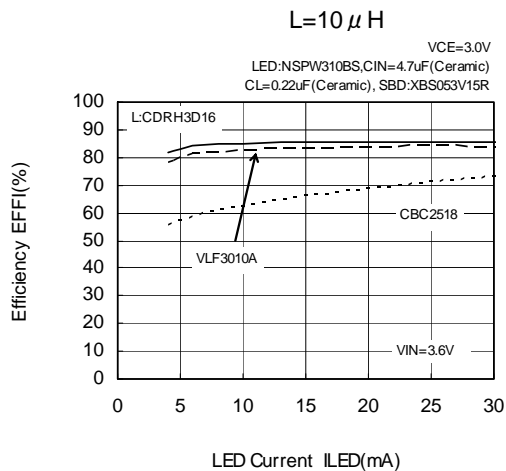

○XC9116B02AMR, 4 LEDs in series

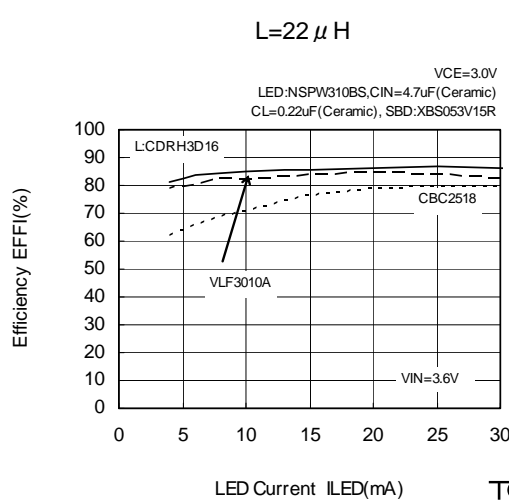
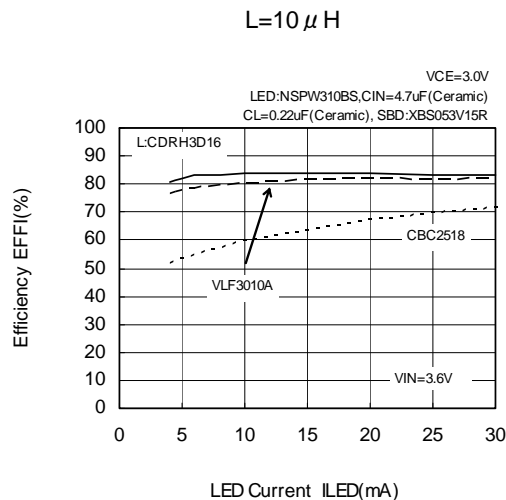

## TYPICAL PERFORMANCE CHARACTERISTICS (Continued)

(15) Average LED Current vs. Input Voltage

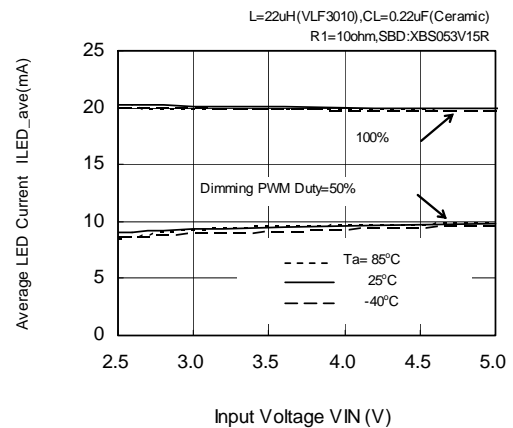
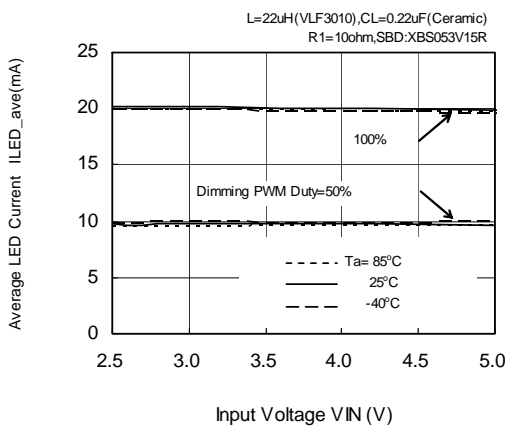
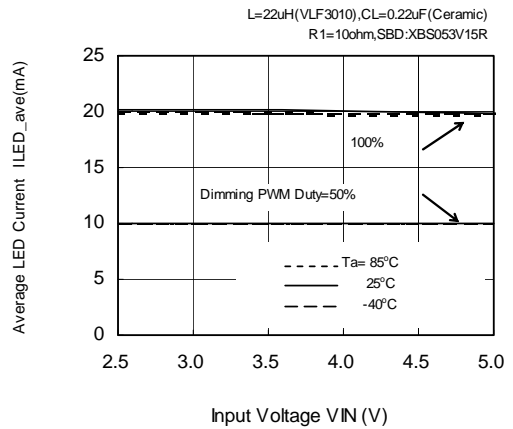
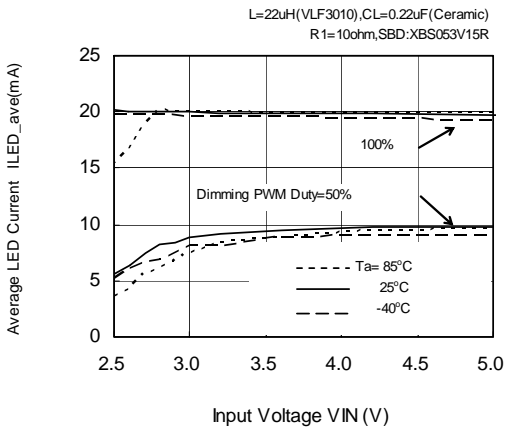
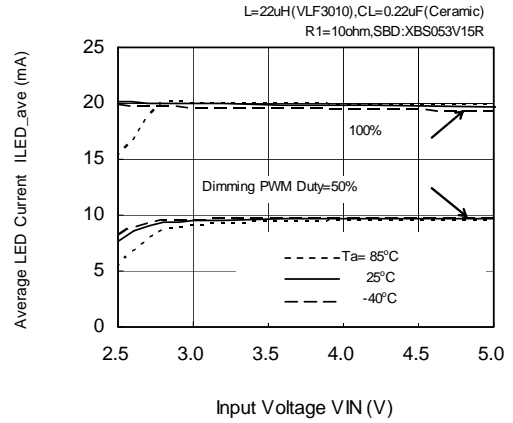
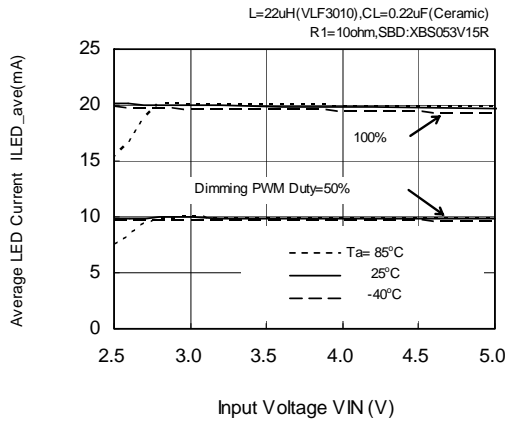

Note : Average LED Current denotes the average current which flows into LED when a PWM signal is input to the CE pin.

## ■ TYPICAL PERFORMANCE CHARACTERISTICS (Continued)

(16) Average LED Current vs. Dimming PWM Duty

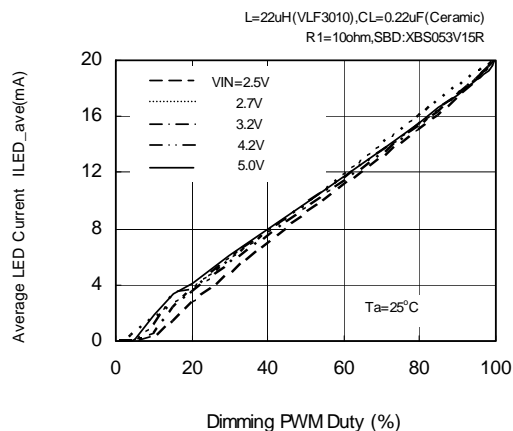
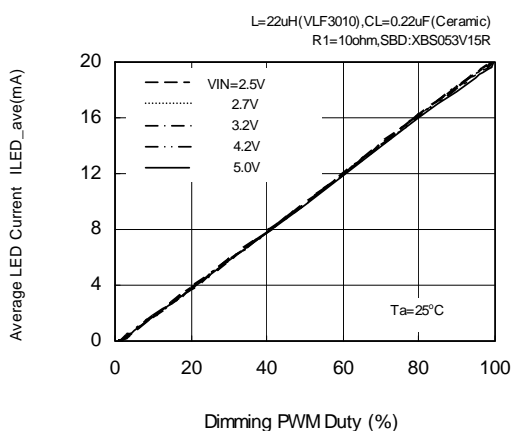
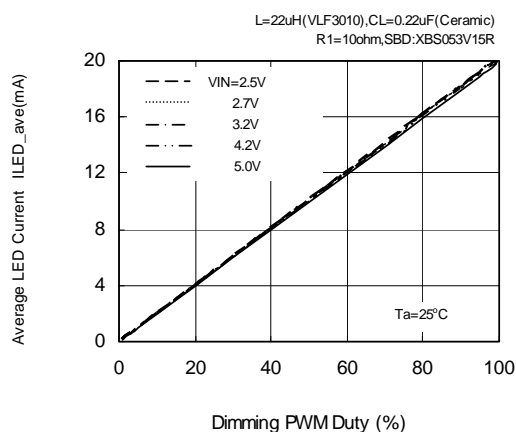
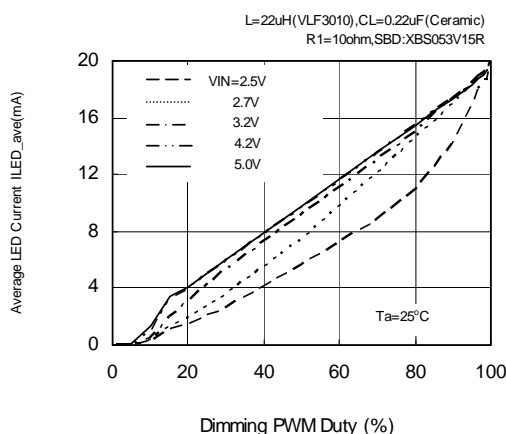
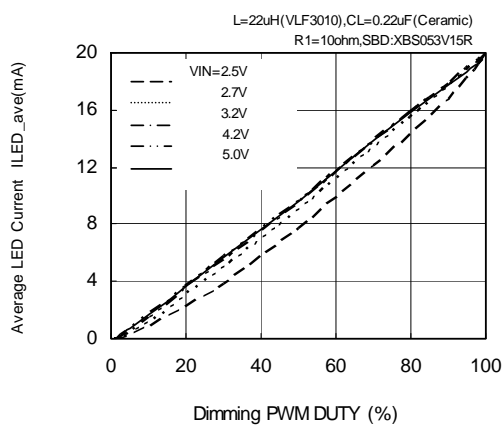
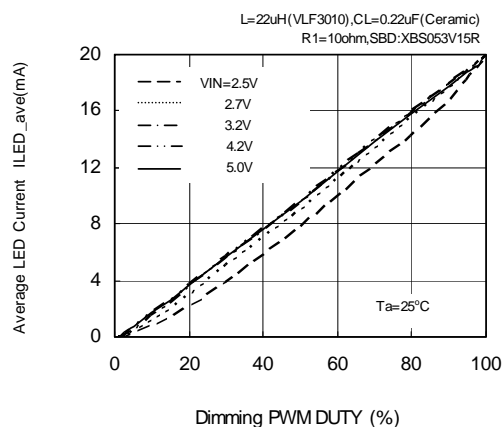

Note : Average LED Current denotes the average current which flows into LED when an PWM signal is input to the CE pin.

## PACKAGING INFORMATION

### ● SOT-25

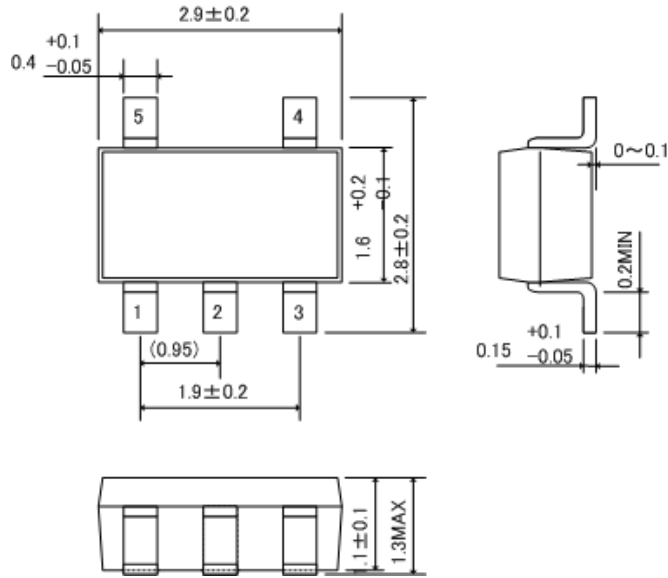

### ● USP-6B

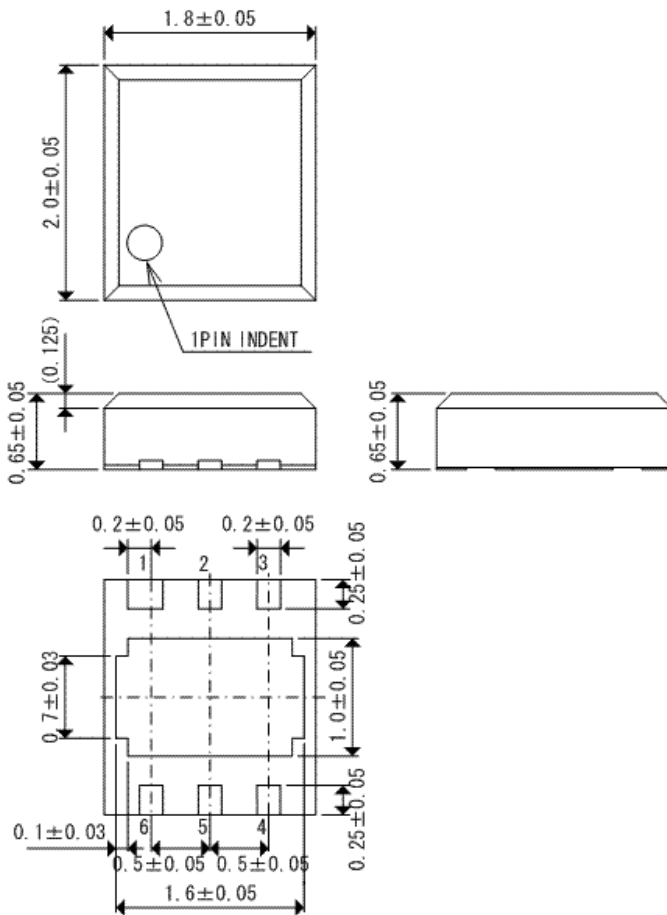

Reference Pattern Layout

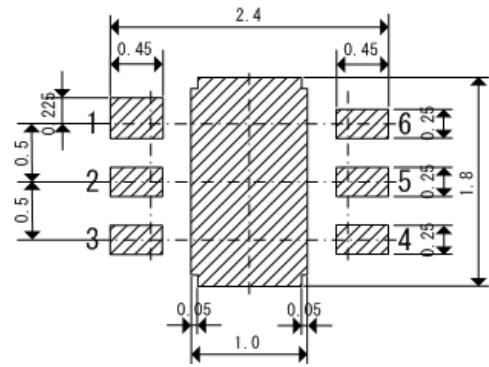

Reference Metal Mask Design

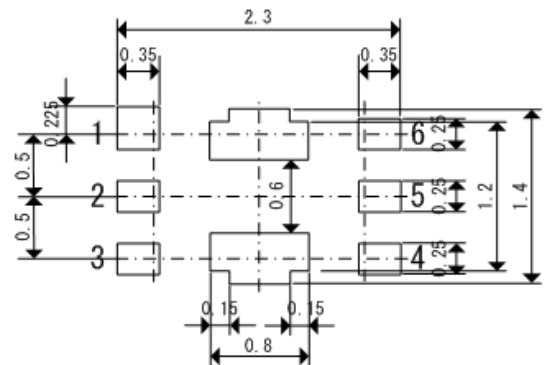

## MARKING RULE

### ●SOT-25

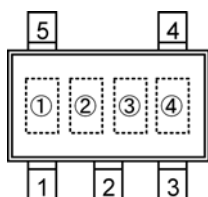

SOT-25  
(TOP VIEW)

① represents product series

MARK	PRODUCT SERIES
F	XC9116 x 02AM x

\* Character inversion used.

② represents Lx overvoltage limit

MARK	Lx OVERVOLTAGE LIMIT	PRODUCT SERIES
B	Available	XC9116B02AM x
D	Not Available	XC9116D02AM x

③ represents oscillation frequency

MARK	OSCILLATION FREQUENCY	PRODUCT SERIES
A	1MHz	XC9116 x 02AM x

④ represents production lot number

0 to 9 and A to Z, or inverted characters 0 to 9 and A to Z repeated.

(G, I, J, O, Q, and W excluded)

### ●USP-6B

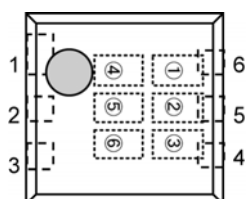

USP-6B  
(TOP VIEW)

① represents product series

MARK	PRODUCT SERIES
K	XC9116 x 02AD x

② represents Lx overvoltage limit

MARK	Lx OVERVOLTAGE LIMIT	PRODUCT SERIES
B	Available	XC9116B02AD x
D	Not Available	XC9116D02AD x

③④ represents FB voltage

MARK		FB VOLTAGE (V)	PRODUCT SERIES
③	④		
0	2	0.2	XC9116 x 02AD x

⑤ represents oscillation frequency

MARK	OSCILLATION FREQUENCY	PRODUCT SERIES
A	1MHz	XC9116 x 02AD x

⑥ represents production lot number

0 to 9 and A to Z repeated (G, I, J, O, Q, and W excluded)

\* No character inversion used.

1. The products and product specifications contained herein are subject to change without notice to improve performance characteristics. Consult us, or our representatives before use, to confirm that the information in this datasheet is up to date.
2. We assume no responsibility for any infringement of patents, patent rights, or other rights arising from the use of any information and circuitry in this datasheet.
3. Please ensure suitable shipping controls (including fail-safe designs and aging protection) are in force for equipment employing products listed in this datasheet.
4. The products in this datasheet are not developed, designed, or approved for use with such equipment whose failure or malfunction can be reasonably expected to directly endanger the life of, or cause significant injury to, the user.  
(e.g. Atomic energy; aerospace; transport; combustion and associated safety equipment thereof.)
5. Please use the products listed in this datasheet within the specified ranges.  
Should you wish to use the products under conditions exceeding the specifications, please consult us or our representatives.
6. We assume no responsibility for damage or loss due to abnormal use.
7. All rights reserved. No part of this datasheet may be copied or reproduced without the prior permission of TOREX SEMICONDUCTOR LTD.

**TOREX SEMICONDUCTOR LTD.**